

view A

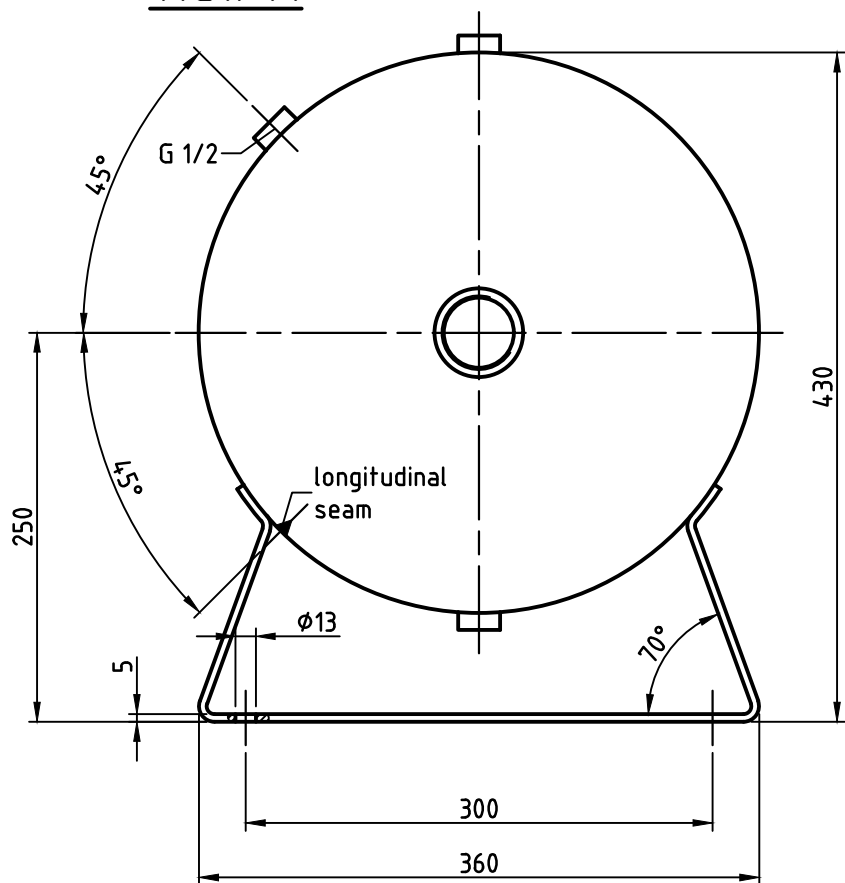

socket welding
 drain and plug socket
 inside flush

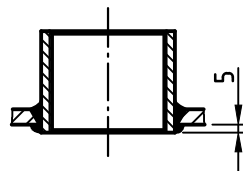

SEAMS (unless otherwise indicated on drawing):			
longitudinal seam	socket-/flangeweldings	circumferential seams	
		beadseams only up to 8mm wall thickness of bottoms cyl. brim > 3,5 x wall thickness of bottoms	

pressure variation :
pressure swing 0-11 bar max. operations 1.000
infinite operation of pressure swing within 20% of 11 bar
operational characteristics / calculation characteristics :
volume V (litre) : 90
max. working pressure PS (bar) : 11
test pressure PT (bar) : 15,73
min. working temp. TS (°C) : -10
max. working temp. TS (°C) : 50
fluid : Druckluft / Stickstoff (Fluidgruppe 2)
location : inside and outside building possible

coating :	
inside : raw	or: inside : hot dip galvanized
outside : primed (if customer wishes lacquered)	outside : hot dip galvanized

manufacturing and testing
 acc. to PED 2014 / 68 / EU - AD 2000

conformity benchmark :	
fluid group : 2	categorie : II
diagram : 2	module : A1 / H

scale:	1:5
our no.:	-
order no.:	-
used for:	M+B Standardvessel
weight:	ca.35 kg
sheet:	1
of sheet:	1
date of plot:	22.06.2015
file:	ENG-010774

	date	name
compl.	22.06.2015	CW
appr.	22.06.2015	SW
follow protection mark acc. DIN 34		

description:	
pressure vessel horizontal 90 l 11 bar	
drawing no.:	revision: A
MB 030602-1.90/E	
drawing no. of design inspection:	date of revision:
MB 030602-1.90	22.06.2015
	revision only on CAD